

Datasheet

Lithium Ion Battery and charger

BIS-0240100R

24 V (26 V) / 10 Ah Battery for Electric Bicycles

Lithium Ion Battery with metal case, base, key, charge and discharge fuse, electronic and charger for electrical bicycles, ready for use.

Technical Data:

Nominal voltage:	24 V (26 V)
Rated capacity C1:	10 Ah
Standard charge:	2 A CC (constant current) charge to 29.4 V, then CV (constant voltage) 29.4 V, until I = 0.5 A
Maximum discharge current:	10 A
Maximum peak discharge current:	30 A (maximum 1 sec.)
Discharge cut-off voltage:	21 V
Operating temperature:	Charging : 0 - 45°C Discharging : -20 - 60°C
Storage temperature:	-20 ~ + 45°C
Weight:	2.6 kg

Dimensions:

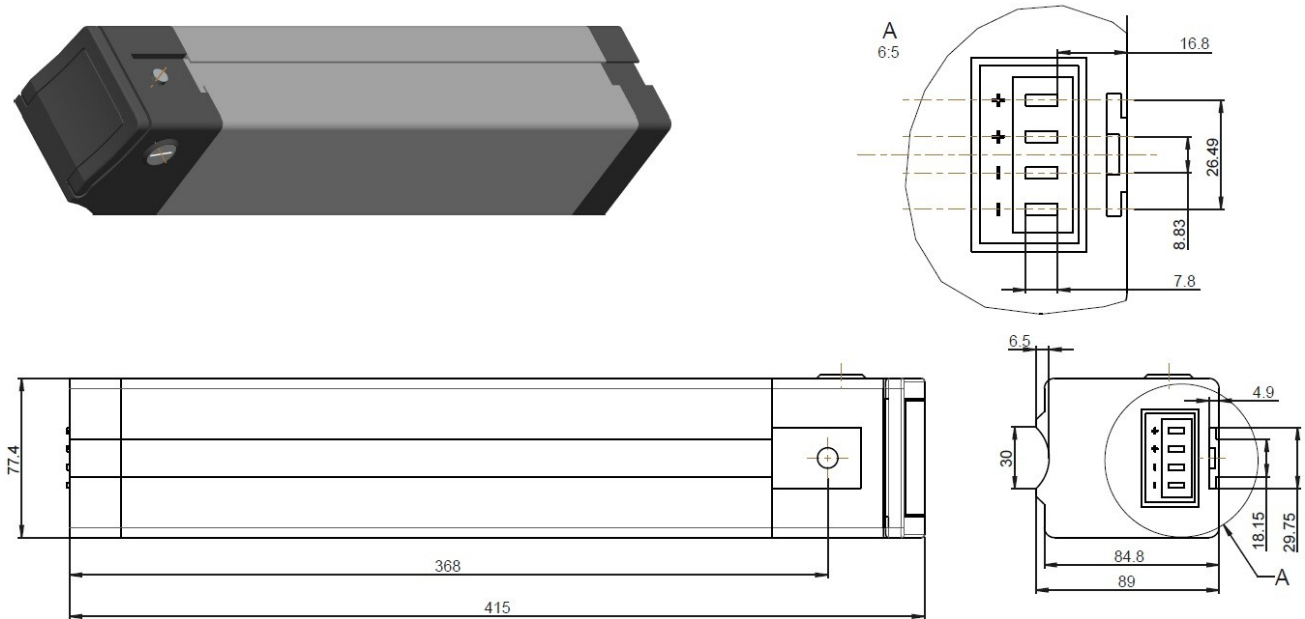

The battery is delivered in a set with a charger, ready to go.

March 2013